

ON-BOARD AUTONOMY FOR A LOW COST LUNAR MISSION

N.D Monekosso
Surrey Satellite Technology Ltd
Centre for Satellite Engineering Research
University of Surrey, GU2 5XH, UK
Ndedi.Monekosso@ee.surrey.ac.uk

Abstract

The lunar mission is to be Surrey Satellite Technology first step to interplanetary travel. SSTL has designed, built and launched twelve low cost microsattellites into LEO, starting in 1981 with UoSAT-1. Design of the next generation of low cost spacecraft, (250-400 Kg) is well underway, with UoSAT-12. This spacecraft is the first in a series of missions planned to qualify SSTL's minisatellite technology and to pave the way for the low cost lunar orbiter. The primary objective of this technology demonstration exercise is to show that low cost interplanetary missions are possible and to validate the minisatellite bus. In keeping with the low cost approach, it is intended that the lunar mission project cost including launch shall not exceed \$15M. This paper discusses how we intend to meet the cost challenge by applying our current low cost practices augmented with autonomy. Spacecraft autonomy will be described specifically in relation to the orbit determination and control sub-system.

1. Introduction

The lunar minisatellite will have as baseline the UoSAT minisatellite. The primary objective of this technology demonstration exercise is to show that low cost interplanetary missions are possible and to validate the minisatellite bus. In keeping with the low cost approach, it is intended that from initial concept to launch, the project will take four years and cost no more than \$15M. One approach to maintaining low cost is to provide autonomy in the space segment. However the implementation of on-board autonomy increases the early project costs and so there must be a trade between on-board autonomy and

reliance on the ground segment for spacecraft operations.

The work described in this paper brings together two on-going research projects, namely the feasibility of the low cost lunar mission and an investigation into spacecraft autonomy as a means for reducing mission costs and risks. In section 2, the SSTL low cost approach and its applicability to an interplanetary mission are discussed. Section 3 describes the lunar mission operations requirements, and section 4 describes the proposed spacecraft navigation and guidance sub-system and a candidate architecture for automating the spacecraft.

2. Background

2.1 Low cost approach at SSTL

The most important distinguishing feature between the proposed SSTL/UoSAT and other lunar missions is the cost. An attempt will be made to reduce it by a factor of ten. In order to see if this is possible we consider what has made SSTL's past and present missions low cost. The factors enabling low costs were identified as

1. Shared launch
2. Relatively benign LEO space environment
3. Company philosophy
 - horizontal management structure
 - Management of risk
4. At the mission design phase, low engineering costs achieved through
 - short development time
 - parts selection e.g. commercial-grade parts where possible
 - sub-systems built where possible in house
 - design for low cost

meeting objective targets rather than performance targets

- spacecraft complexity, GG stabilised, no orbit control
5. During mission lifetime
- low spacecraft operations cost.

In the next section the applicability of these factors to the lunar mission will be considered.

2.2 Can low costs be maintained for the lunar satellite ?

The philosophy adopted at the mission definition phase translates into lower costs at the mission design phase.

A shared launch into GTO was chosen for the lunar mission based on costs and frequency of launches. However the radiation environment is very severe, and the time spent in the initial GTO orbit must be kept short. This has an impact on the size and hence costs of the propulsion system.

The management structure style translates into reduced development time, design decisions are devolved to the lowest possible level compatible with product assurance. The microsatellites are designed, built, and launched in 18 months. The lunar mission project is expected to last four years, from feasibility study to launch, it is intended that spacecraft development will last approximately 18 months.

The LEO space environment, the approach to risk acceptance together with in-house space qualification have permitted the successful use of commercial-grade parts on UoSAT microsatellites. The lunar spacecraft will be subject to a more severe environment. A simulation of the radiation environment was carried out¹, the results of which will drive the parts selection, procurement and qualification.

The UoSAT spacecraft complexity and the degree of ground segment automation means that operations costs are low. High operations costs generally result from complex attitude and orbit determination and control requirements e.g. orbit maintenance, attitude control management. The lunar mission operations costs will be more difficult to maintain low. The attitude and orbit

control requirements will be significantly more complex than the SSTL/UoSAT microsatellites thus requiring more intensive manned supervision especially in the early phases of the mission.

Substantial on-board autonomy can help maintain lower costs provided that the additional R&D costs (costs of autonomy) are less than the costs of manual operations.

3. Lunar spacecraft operations

The planning and scheduling of UoSAT spacecraft operations tasks, is performed on the ground and uplinked to the spacecraft. The ground segment is automated, ground station computers communicate with the spacecraft during 'passes' lasting 10-15 minutes.

The lunar mission will have significantly different operations requirements. In general, the operations requirement for a given mission depends on spacecraft complexity, and visibility. For example, a spacecraft with no *active* stabilisation and no orbit control require far less commanding than an actively controlled.

3.1 Operations requirements

A primary mission constraint is that all nominal operations are to be performed from the University of Surrey (UoS) mission control. The secondary ground station is intended primarily for extending downlink time. During the trans-lunar cruise, visibility is good, contact lasts a few continuous hours daily.

In nominal conditions, the main operations activities are spacecraft tracking, orbit control activities, payload task scheduling and data downloads.

3.2 Proposed communication system

The results of the feasibility into a low cost lunar mission are discussed in [Monekosso96-a]¹. A summary of main points is given here. It is intended to use a 1.5 m groundstation dish at UoS-Guildford (UK) for mission operations. With a secondary ground station in the southern hemisphere, at approximately the antipode of UoS, up to 12 hours communication is expected daily. The

Rutherford Appleton Laboratory (UK) 12 m antenna is under consideration for use as back up for non-nominal operations.

The proposed frequencies are S-band for housekeeping and payload operations. On-board the spacecraft, two omnidirectional antennas will provide continuous coverage for housekeeping during all mission phases. A fixed 1m parabolic dish will provide a higher data rate uplink and downlink. The expected maximum bit rates are 575 b/s downlink and 355 b/s uplink with the omnidirectional antenna and 727b/s uplink and 196Kb/s downlink with the directional antenna.

4. The lunar spacecraft

There is a high degree of automation in both the current UoSAT space and ground segments. The microsatellite bus structure has evolved to become increasingly automated. The spacecraft bus architecture has characteristics that will accommodate higher degrees of automation without significant change. The design is modular both from the structural and electrical perspective. From the electrical perspective, each bus sub-system already possesses the architectural requirements for automation, namely a controller. All sub-systems and payloads contain a microcontroller and have limited autonomy with respect to the general purpose on-board computers (OBC) and the ground segment. Sub-systems without a dedicated computer are controlled by any one of the OBC. In addition new developments such as the distributed telemetry and telecommand and high speed communications link between the various on-board computers currently being validated pave the way for higher levels of autonomy. Recent research at UoSAT has validated a Global Positioning System (GPS) receiver for autonomous navigation in LEO. The inclusion of a propulsion system in the UoSAT-12 minisatellite is the first step in developing autonomous guidance.

4.1 Proposed lunar navigation and guidance system

The sub-system will combine ground and space based orbit determination. S-Band tracking will be the primary ground based method. The spacecraft will propagate orbit knowledge on-board and will be updated with new orbital parameters at regular intervals. For high accuracy 3 tracking stations are necessary although tracking is possible (albeit degraded accuracy) with a single station¹ using a filtering technique.

An autonomous on-board orbit determination system will complement ground tracking, to provide coarse orbit knowledge. Two system are under consideration, one based on an Inertial Measurement Units (IMU) and the second method based on star and planet sensing. With the IMU system, the navigation unit must be provided with initial parameters and updated regularly depending on the IMU drift rate. The S-Band tracking system can provide the updates. The IMU system is intended only for manoeuvring phases. For a highly autonomous spacecraft, an IMU alone is inadequate without on-board a system capable of updating frequently. The advantage of a star/body sensor is that both attitude and orbit determination could be provided using the same sensors².

A semi-autonomous approach to navigation and guidance is proposed for this lunar mission. Manoeuvre planning is implemented at the ground station, and execution control is overseen by the navigation and guidance computer. Table 4-1 from [Monekosso96-a]¹ shows the proposed distribution of functions between on-board computers and ground station computers.

	Propagation	Determination and Propagation	Control
Attitude	Precise at GSN Coarse OBC	Coarse OBC, corrections by GSN	OBC
Orbit	Precise at GSN Coarse OBC	Coarse OBC, corrections by GSN	Scheduled at GSN

Table 4-1 Space / Ground function distribution

4.2 Automating the navigation sub-system

How will the proposed sub-system described in 4.1 be automated? The feasibility of a highly autonomous spacecraft control architecture is under investigation. The proposed architecture should satisfy a range of space/ground segment automation distribution. The preliminary architecture definition is described here. It draws inspiration from works in the area of mobile robots, and telerobotics, namely the Brooks subsumption architecture³, NASREM⁴, and in the area of spacecraft control^{5,6}. The navigation system is composed of basic functions or modules. The functions are for example, orbit determination, orbit propagation, and manoeuvre planning. These functions are used as building blocks to achieve goals which are complex operation's activity. Examples of such goals are

1. dump momentum
2. V Manoeuvres for orbit control,
3. spin up/down using reaction control thrusters
4. predict time to next eclipse(s)
5. propagate orbit to determine time to next payload activity

Goals can be generated internally or externally. For example, goals 4, and 5 above are generated externally by an intelligent sub-system or payload. An autonomous navigation system will determine that a manoeuvre correction is necessary, plan and execute it. This is an internally generated goal.

Figure 4-1 below shows an architecture for the navigation system. The foundation for this architecture is the generic autonomous navigation system described by Marshall⁷. In this context, the modules are treated as black boxes. The manner in which they interact constitute the control architecture. These black boxes have requirements that must be met and hence place constraints on the architecture. The control structure can be implemented in a number ways, each with advantages. In this implementation, the key points are

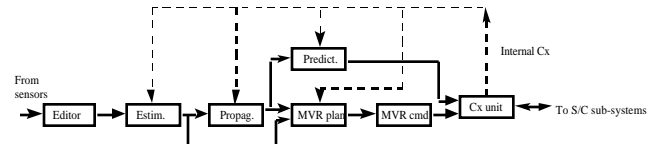

Figure 4-1 Autonomous navigation system

- no overall controller within sub-system
- each block or module within the system has a speciality
- each block runs asynchronously and continuously (within limitations of on-board computer)
- operation is based on cycles, a cycle consists of an (input, compute, output) phase

The system's operation is cyclical. During the input phase, the output of the preceding module is captured. The input is processed during the compute phase, then made available at the output in the third phase.

4.2.1 Scenarios

Three examples are described below to illustrate the operation of the autonomous sub-system.

case 1 : goal is 'predict time to next eclipse'

The request arrives via the communication unit (see Figure 4-1), and is passed to the predictor on the action request (internal communication) link. The current estimated orbit parameters are used by the predictor. The results are returned to the communication unit on the data path.

case 2 : 'nominal operation' (no external goals)

In nominal operation, the modules in Figure 4-1, operate continuously, unless terminated by a command. Sensor data is processed, the orbit determined and propagated. If a correction is deemed necessary, a manoeuvre is planned and executed. The nominal trajectory to the Moon may be stored on-board, and / or updated by ground control.

case 3 : 'goal is execute a ΔV Manoeuvre'

During nominal operation, the time has come for a previously scheduled

manoeuvre to be executed. The necessary information may be stored in the form of pre-compiled manoeuvres or simply as a nominal orbit to maintain in a very advanced system.

4.2.2 Implementation

How does this architecture relate to the proposed system for the lunar mission? Looking back at Figure 4-1, the functional modules or blocks are independent and asynchronous. The ultimate aim is for all modules to be implemented on-board. A key requirement for the project is incremental development. Thus the architecture must accommodate functions operating both on-board and on the ground.

In practice each module does not wait on the preceding but uses whatever is found in the output buffer. It is important to ensure that the output buffer is never dangerously out of date. The implementation for the lunar spacecraft will have an on-board estimator. Data editing and propagation are expected to be on-board, whereas manoeuvre planning will be ground based, and uploaded as pre-compiled sequences.

4.3 Proposed spacecraft architecture

This section describes how the autonomous sub-system (in section 4.2) is integrated into the spacecraft. The spacecraft is made up of autonomous sub-systems similar from the architectural point of view but each having a different functional speciality. Figure 4-2 shows the autonomous sub-systems within the spacecraft while Figure 4-3 shows a generic autonomous sub-system. No single sub-system has a supervisory role. They do have a single common top level goal and must co-operate in planning and executing this goal.

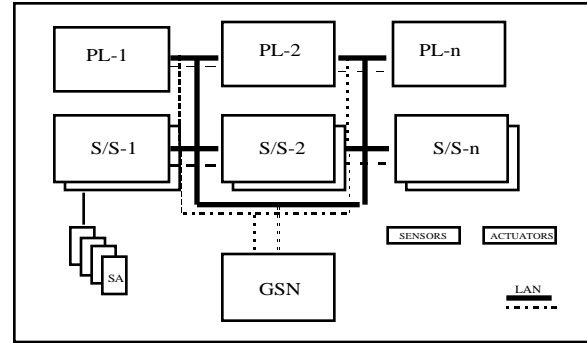

Figure 4-2 Spacecraft architecture

Each sub-system has responsibility for its specialisation. In this scheme, the ground operator is another autonomous sub-system, whose roles include

- to generate top level goals
- to act as a general purpose autonomous system
- to act as a knowledge base
- to take over the role of one or more specialist modules on-board if necessary
- has override capability

Each intelligent sub-system has knowledge of itself and of the others in the form of models. The purpose of maintaining models is to facilitate co-operation. The generic model has the form⁸

1. *name*
2. *address*
3. *skills*
4. *goals*
5. *plans*

The name and address fields are used for communication purposes. The skills relate to what the system can or cannot do. This is a dynamic field, for example a partial system failure may require re-defining skills. In the event of a system having multiple sub-goals or tasks, these are described in the goals field. An autonomous navigation and guidance system may have planned a series of future manoeuvres to be performed, these are described in the plan.

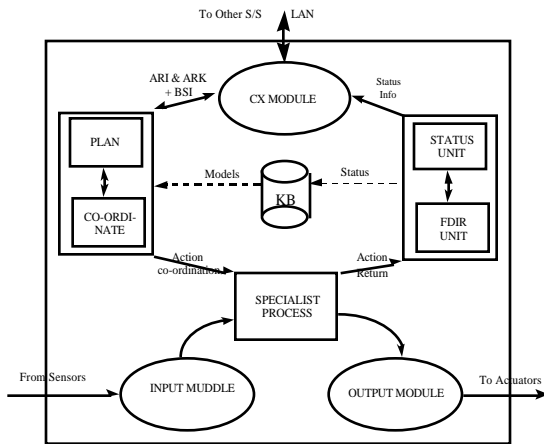

Figure 4-3 Generic autonomous sub-system

The generic autonomous system in Figure 4-3 has the basic input, compute, output structure. The compute unit differs from sub-system to sub-system, and provides the specialist functions. The communication unit is similar for all. The FDIR unit provides fault detection and recovery, this could be as simple or as complex as needed. The status unit generates the telemetry and audit trail. This information is filtered and either directly transmitted to ground or stored on-board. The audit trail generator keeps a log of decisions, actions, and outcome of actions. The functions of the co-ordination unit is described in section 4.3.1. It contains the knowledge base. The control structure it is intended to use will superimpose a more abstract reasoning level over the low level (reactive) control within the computational limitations of a small satellite.

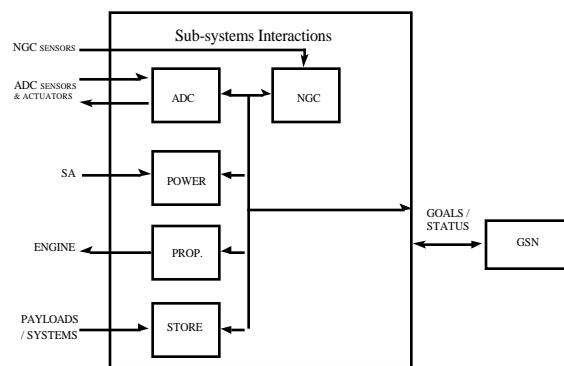

Figure 4-4 Spacecraft sub-system interaction

The navigation and guidance unit in Figure 4-4 will have a model of all sub-

systems with which it directly interacts, including itself.

4.3.1 Communication and co-operation

Each intelligent sub-system has a communication unit. The messages generated within a sub-system are used to

- inform other sub-systems of planned events thus avoiding conflict of interest,
- resolve conflict as they arise e.g. resource shortages,
- inform others of unplanned events such as local faults.

Messages are directed to a specific sub-system, for example to request information or to send a task request. Messages may be a general broadcast to all. In the latter case, sub-systems will act on the information or command only if appropriate. The types of messages anticipated are

- action request to a specific sub-system e.g. ODCS send a command to ADCS for a particular attitude mode,
- action request acknowledgement,
- broadcast information e.g. status information regarding availability of resources. Note that a resource may be battery power, or bandwidth, or partial failure of a sub-system/module

From a practical point of view, the communication will be over the existing local area network (LAN) which connects all sub-systems.

Co-operation entails exchanging action requests, and intention and status information between sub-systems. Intention information describes tasks planned within a sub-system that may be useful to others in their planning. For example, the navigation and guidance system will inform housekeeping systems and payloads of manoeuvres (time, duration, attitude and power requirements), it may have priority in which case payloads with incompatible attitude requirements will not attempt to operate. A priority structure will determine who should and should not operate in the event of resource (e.g. power) limitations. Status information

will be openly broadcast to indicate changing sub-system resource status (bandwidth, non-critical fault conditions, etc.). A request may be made for a sub-system to perform an action.

The co-ordination unit will contain the knowledge, where the information are constraints and constraints relaxation. Conflicts arise because of constraints on resources and are resolved through the application of constraint relaxation and tasks prioritisation for resource management. An example of conflict is maintaining sufficient power during a propulsion manoeuvre. The conflict between two independent tasks running asynchronously, (one ensuring that the solar panel Sun angle remains within a band, and the manoeuvre task requesting an attitude incompatible with the Sun angle requirement) must be resolved. For every constraint there is one or more corresponding relaxation.

In the practical implementation, the representation of the constraint and constraint relaxation information will depend on the type of information. Most of the constraint information can be reduced and represented as relational operations augmented with rules. However this simplification may not achieve the best results. The choice of representation will depend on speed of response, graceful degradation, support for inaccurate sensing, etc. All of which ultimately are dictated by on-board processing capability (and reliability issues).

4.3.2 Generation of goals and tasks

Goals (or commands) for sub-systems are generated internally or externally. The navigation, guidance, and control unit will generate attitude goals for the attitude control sub-system, and both will generate goals for the propulsion system. Similarly the power system can request of a sub-system or payload to enter a low power mode. The ground segment has the capability for goal generation for all sub-systems and payloads.

A top level goal must be broken down into sub-goals. Whether on the ground or on-board, this problem can be reduced to

one of generating and scheduling sub-goals or tasks according to a procedure. Given the goal, go to the Moon, very coarsely the steps are

1. select one trajectory option
2. formulate a coarse plan for option
3. detail manoeuvres (manoeuvre planner)
4. generate manoeuvre commands
5. sequence commands and co-ordinate with other sub-systems
6. execute and monitor execution of commands
7. verify every step and re-plan as necessary

The execution of such a procedural problem can be planned using a skeleton plan. These were inspired by TCA task trees⁹ for mobile robots. A skeleton plan is a AND-OR tree from which a plan is generated. An example is shown in Figure 4-5 where the circles are the nodes or tasks that must be completed. The & signifies that the two sub-tasks e.g. B11 and B12, must be completed in order to achieve the parent task B1. On the other hand only B1 or B2 need be completed to satisfy task A. Horizontal lines represent temporal information. Task A must be completed before B can begin.

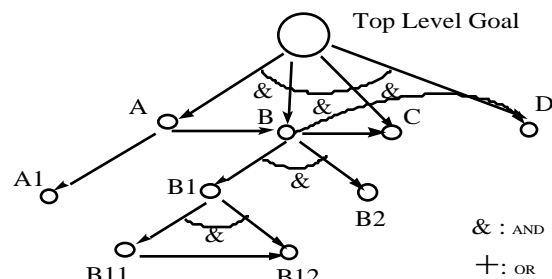

Figure 4-5 An example of a skeleton plan

The tree structure shown in Figure 4-5 is used in a prototype to plan the autonomous capture of an image with the UoSAT Earth imaging system [Monekosso96-b]¹⁰. Selection between alternative paths (+) was based on

1. priority information (pre-compiled)
2. resource availability (dynamic)

The skeleton plans are continuously updated i.e. any invalid branch (corresponding to a resource shortage) is

removed from the tree either temporally or permanently. If the removal of a branch means that the plan as a whole cannot be used, then the plan is disabled effectively removing it from the database.

4.4 Ground support

This section describes the ground segment functions required to support the autonomous navigation and guidance system. In the case of the lunar mission, the ground support should include spacecraft tracking to update the IMU orbit determination and manoeuvre planning. Verification will be performed on-board.

The extent of ground support required can slide back and forth on a scale from limited support to continuous tracking, depending on the extent of autonomous functions implemented on-board and of course on the spacecraft status. If, for a future UoSAT minisatellite, a precise and independent orbit determination e.g. based on Sun, star, or planet observations were to be developed, then ground support would slide towards minimal. The ground segment is just another autonomous sub-system. In nominal conditions it will have a non-supervisory role but in non nominal conditions it has override capability and plays the role of a controller under operator's supervision.

4.5 Pros and cons of architecture

The architecture has the following advantages

1. Building blocks and sub-systems are loosely connected and so operate independently,
2. A faulty module or sub-system has limited affect on others, and can be replaced in some cases by the ground station allowing graceful degradation
3. Smaller well defined modules to build and test, using previously validated modules
4. Architecture is suited to incremental build
5. Architecture is suited to present UoSAT spacecraft architecture

and the disadvantages are

1. Distributed control implies more hardware and hence higher power consumption
2. Co-ordination between sub-systems may be difficult if the communication bandwidth is limited

With regards to the first disadvantage, as a result of the 'commercial grade' policy, the implementation can take advantage of the more powerful and lower power devices on the market. Co-ordination is based on message passing. Messages are kept to a minimum, and it is conceivable to have a dedicated redundant LAN for co-ordination message passing alone.

4.6 Reliability concerns

The UoSAT microsattellites to date are inherently 'safe'. This will not be the case with the lunar minisatellite. It is intended to deal with the increased risk with autonomous fault tolerance. However 'too much' autonomy results in complex systems which can reduce reliability. By allowing the piecemeal introduction of autonomous features even within the life time of a spacecraft, verification and validation becomes incremental.

5. Space versus Ground automation

The trade between ground and space automation depends on mission type (payloads), spacecraft visibility and one-way light time, risk acceptance and costs. The correct balance must be achieved to optimise a mission in terms of costs versus product return. This architecture attempts to produce spacecraft with varying degrees of space/ground automation mix to satisfy a given mission and a given degree of risk acceptance and technological know-how. In addition the proposed implementation is such that the automation mix can slide back and forth on the scale at any time during the mission according to the status of the spacecraft. Of particular interest to the current research program is the trade of

space/ground automation in the context of risk reduction.

Ultimately, the autonomy research program aside from the lunar project, is biased towards automation in the space segment because it is in the author's opinion that small, low cost, and highly capable satellites are necessary for space exploration beyond near Earth planets.

6. Future work

The work began with an analysis of the operations tasks during the all mission phases, and will continue with a detailed analysis of a manoeuvre task. In the next phase, the autonomous navigation and guidance sub-system will be implemented. The roles of the ground segment sub-system must be specified for all the possible distribution of autonomy in the ground and space segments. This state information is encapsulated in its specialist modules.

Verification and validation (V&V) is a difficult problem in a system of such complexity. V&V activities will be developed along side the system implementation. It is intended to carry out a risk analysis.

7. Conclusion

The definition of a highly autonomous spacecraft control system was described in this paper. The architecture is based on a distributed intelligence concept. By maintaining a common interface between sub-systems and modularity, the proposed architecture should satisfy a range of space/ground segment automation mix.

Acknowledgements

Special thanks to C. Lindley (CSIRO Division of Information Technology, Australia) and Y. Hashida (Surrey Satellite Technology, UK) for their very useful advice.

References

1. [Monekosso96-a] Monekosso N.D. et al, Feasibility of a Low Cost Lunar Mission AMSAT-UK Colloquium 1996
2. [Hosken95] Hosken R.W. Microcosm Autonomous Navigation

System on-orbit Operation AAS 95-074

3. [Brooks86] Brooks R. A Robust Layered Control System for a Mobile Robot IEEE J. Robotics & Automation volRA2 03/1986
4. [Albus89] NASA / NBS Standard Reference Model for Telerobot Control System Architecture (NASREM) NIST Technical Note 1235, 1989
5. [Gat96] Gat E. News from the trenches : An overview of unmanned Spacecraft for AI researchers, 1996 AAAI spring Symposium. on planning with incomplete information. for robot problems
6. [Aljabri95] Highly Autonomous Event-Driven Spacecraft Control'. Acta Astronautica vol. 35 supplement. 1995
7. [Marshall82] Goals for Air Force Autonomous Spacecraft 1881 USAF Report st-tr-81-72 JPL Report 7030-1- Issue 1
8. [Rich93] Rich E, Knight K. Artificial Intelligence McGraw Hill 1993
9. [Simmons94] Simmons R.G. Structured Control for Autonomous Robots IEEE Trans.Robot.&Autom.v10 no1 Feb. 1994
10. [Monekosso-b] Monekosso N.D Architecture of a Direct Imaging Service, internal report

Biography

Ndedi Monekosso is a Research Engineer in the On-Board Data Handling group at SSTL, and has been involved in the Spacecraft Autonomy research project since Oct. 1995.