

Table of Contents:

- 1.....Cover sheet
- 2.....R750, Data/Address (Section A)
- 3.....R750, L2Cache, Interrupts & Clocks (Section B)
- 4.....R750 (Section PWR)
- 5.....BRIDGE, CPU Bus Interface (Section A)
- 6.....BRIDGE, Memory Control Interface (Section B)
- 7.....BRIDGE, PCI, JTAG, UART & PIDs (Section C)
- 8.....BRIDGE, Pwr & Gnd (Section PWR)
- 9.....SUROM
- 10.....SDRAM
- 11.....Osc/Voltage Regulator/Front Panel Conn., J7
- 12.....R-Packs
- 13.....Capacitors
- 14.....PCI 10 OHM Stub Termination
- 15.....PCI Connector, J1
- 16.....PCI Connector, J2

REVISIONS

CHK	ENG NOTICE	REV	DESCRIPTION	DATE	APPROVED
/					

REV STATUS OF SHEETS (DO NOT USE ON SPECIFICATIONS)	SHEET	1	2	3	4	5	6	7	8	9	10	11	12	13	14	15	16			
	REV	B	B	B	B	B	B	B	B	B	B	B	B	B	B	B	B			
	SHEET																			
	REV																			
	SHEET																			
	REV																			
	SHEET																			
	REV																			

CONTRACT NO.		LOCKHEED MARTIN		FEDERAL SYSTEMS MANASSAS, VA 20110	
PREPARATION	DATE	TITLE Logic Diagram X2000 SYSTEM FLIGHT COMPUTER			
DESIGN CHECK	DATE				
DRAWING CHECK	DATE				
DESIGN APPROVAL	DATE				
OTHER APPROVAL(SPECIFY)	DATE	SIZE	CAGE CODE	DRAWING NO.	REV
		B	52088	LD234A511	B
SCALE		WT		SHEET 1 of 16	

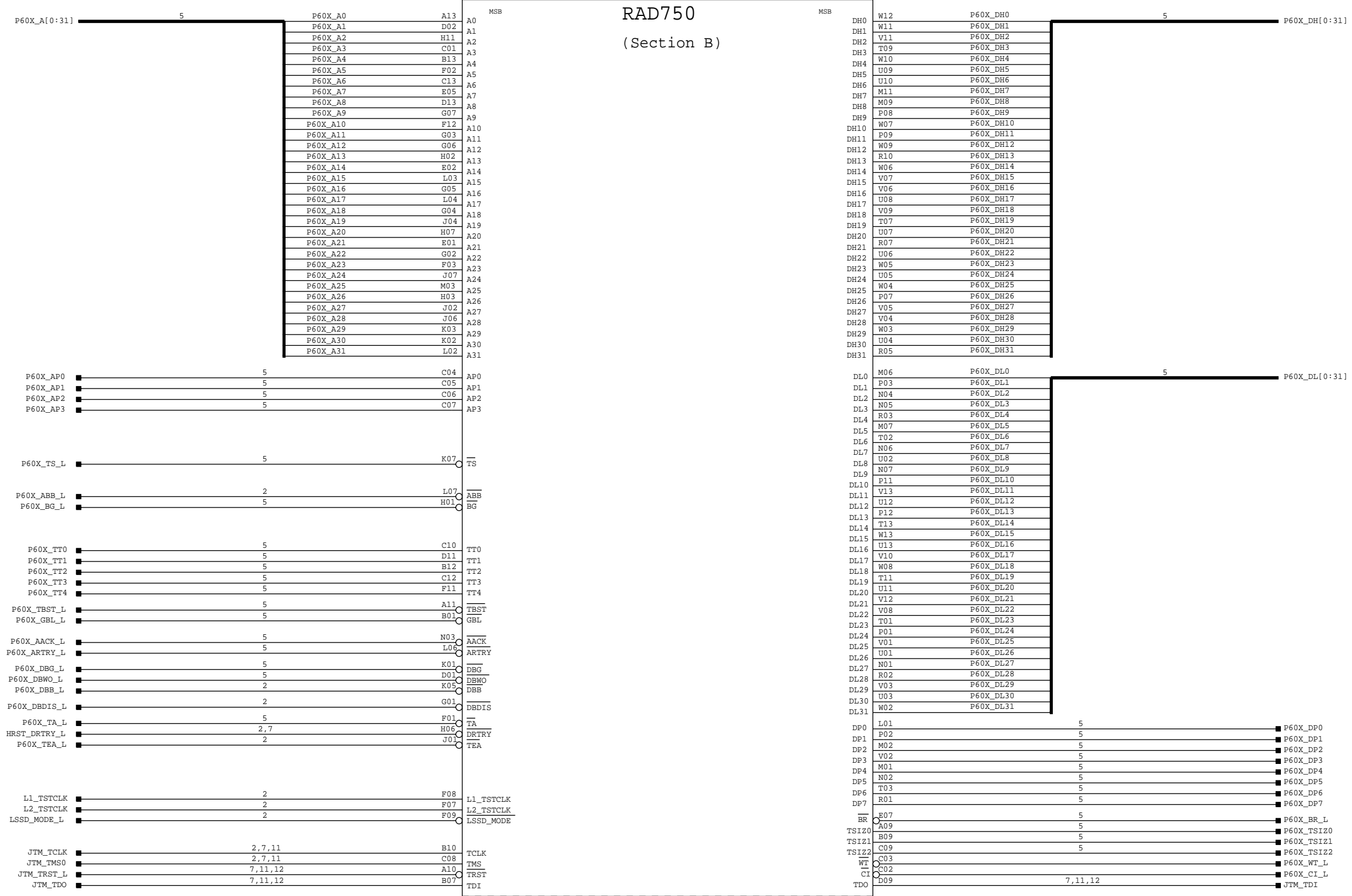

A
RAD750
S5

SIZE B	CAGE CODE 52088	DRAWING NO. LD234A511
X2000 SYSTEM FLIGHT COMPUTER		RAD750 CPU (SECTION B)

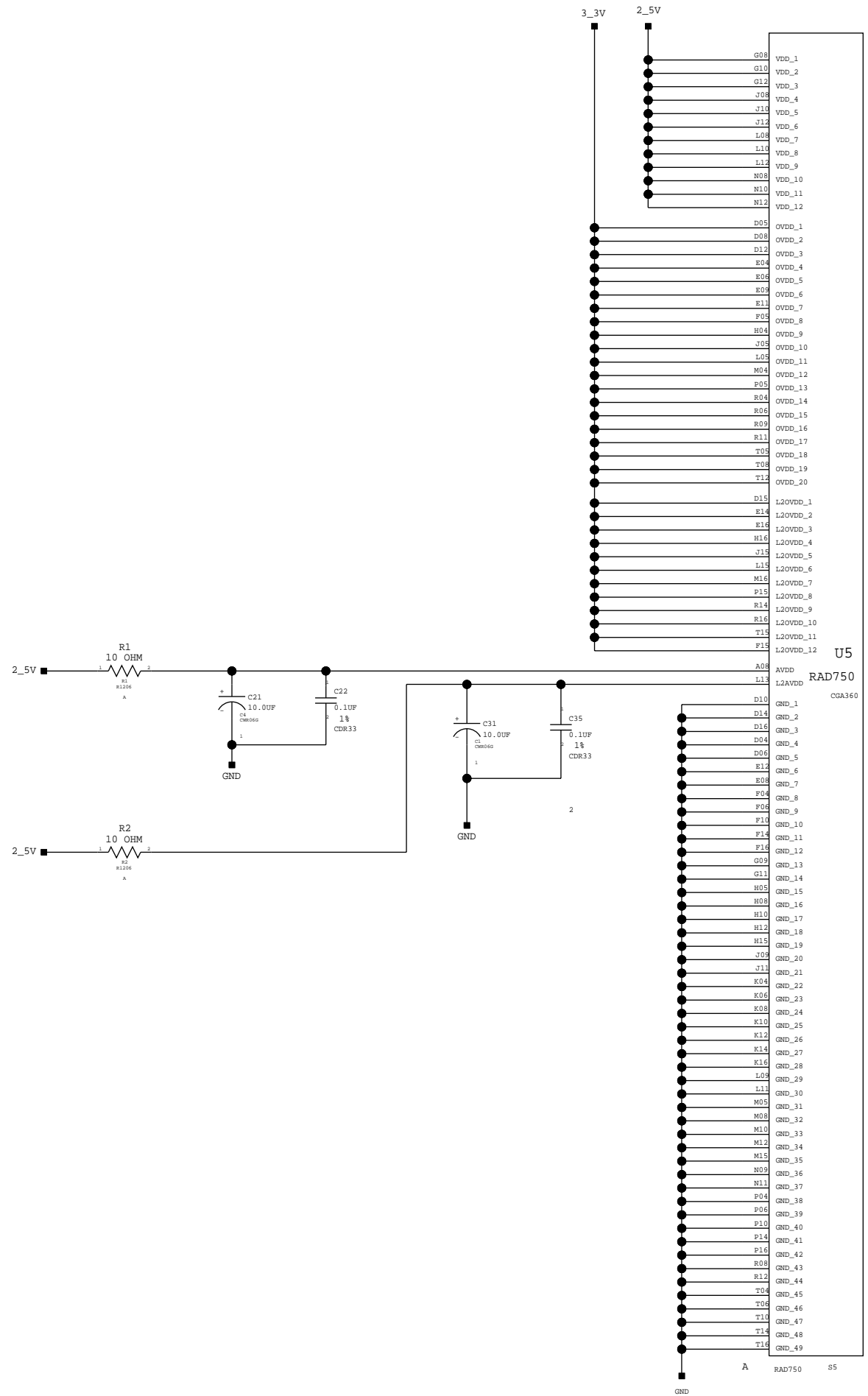

SIZE	CAGE CODE	DRAWING NO.	LD234A511
B	52088	RAD750 CPU (POWER SECTION)	

U16

POWERPCI
60X CPU Bus Interface(Section A)

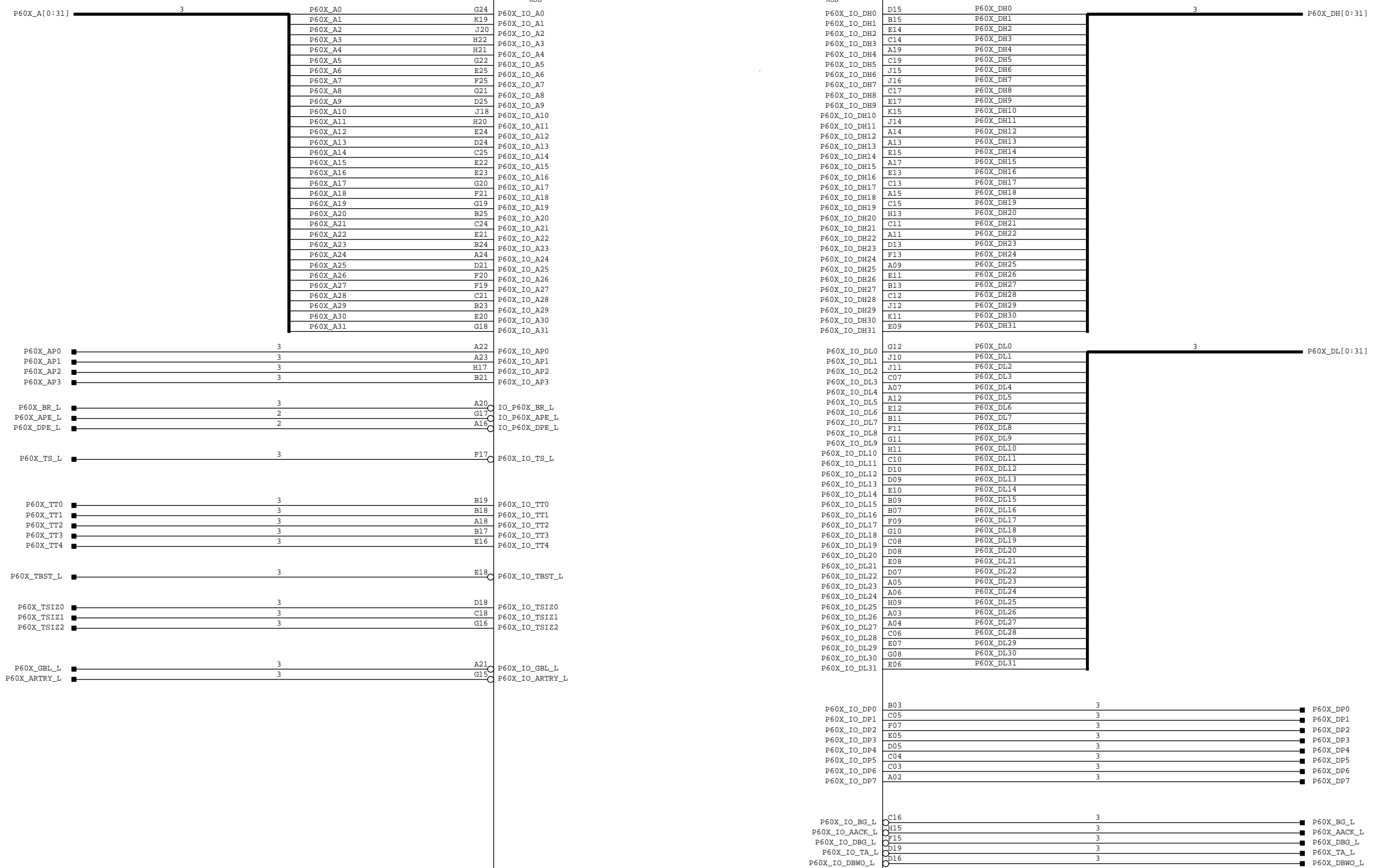

POWERPCI
S8

SIZE	CAGE CODE	DRAWING NO.	LD234A511
B	52088	POWER PCI BRIDGE (SECTION A)	

U16

POWERPCI

Memory Control Interface (Section B)

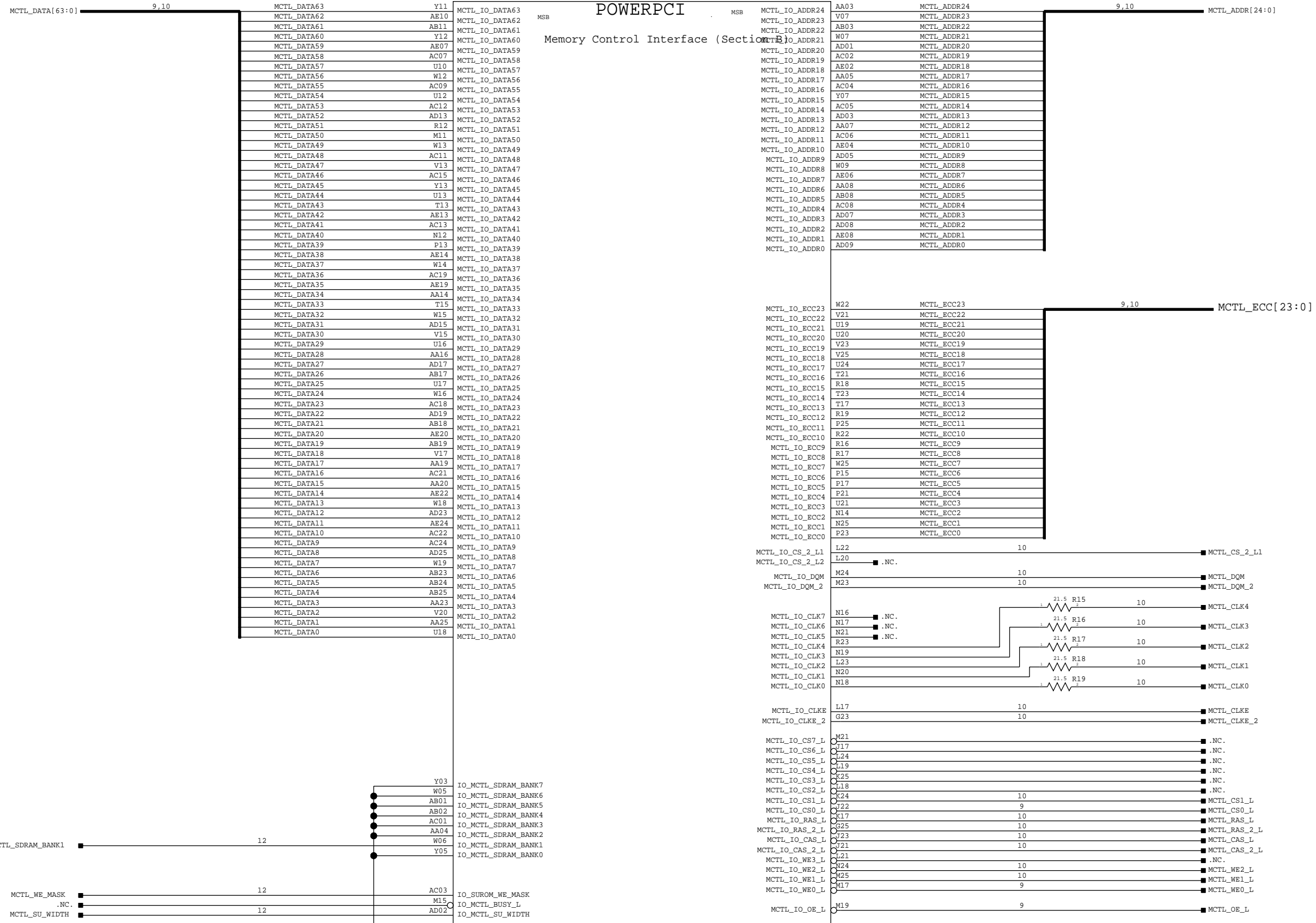

U16

POWERPCI
(Section C)

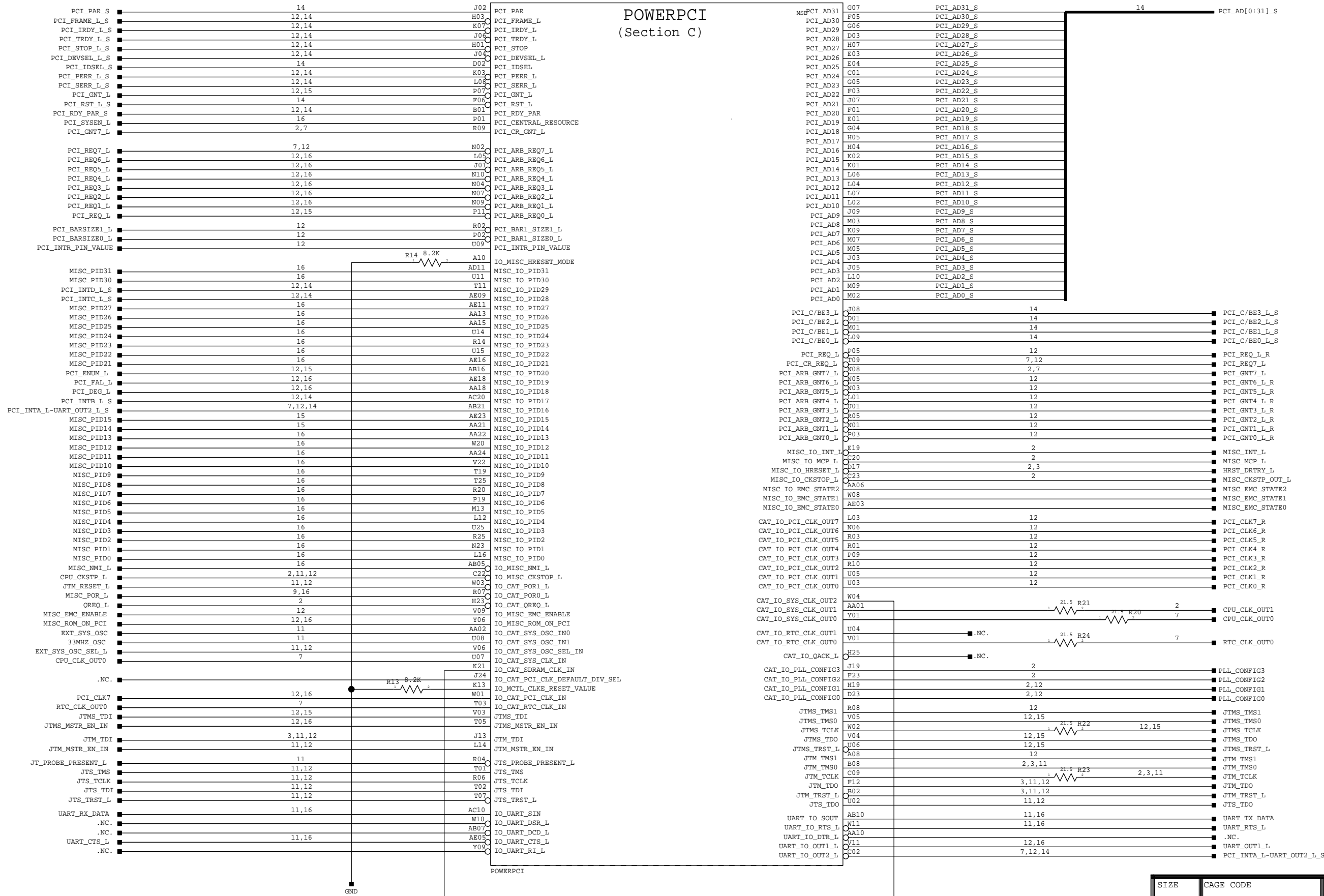

SIZE	CAGE CODE	DRAWING NO.	LD234A511
B	52088	POWER PCI BRIDGE (SECTION C)	

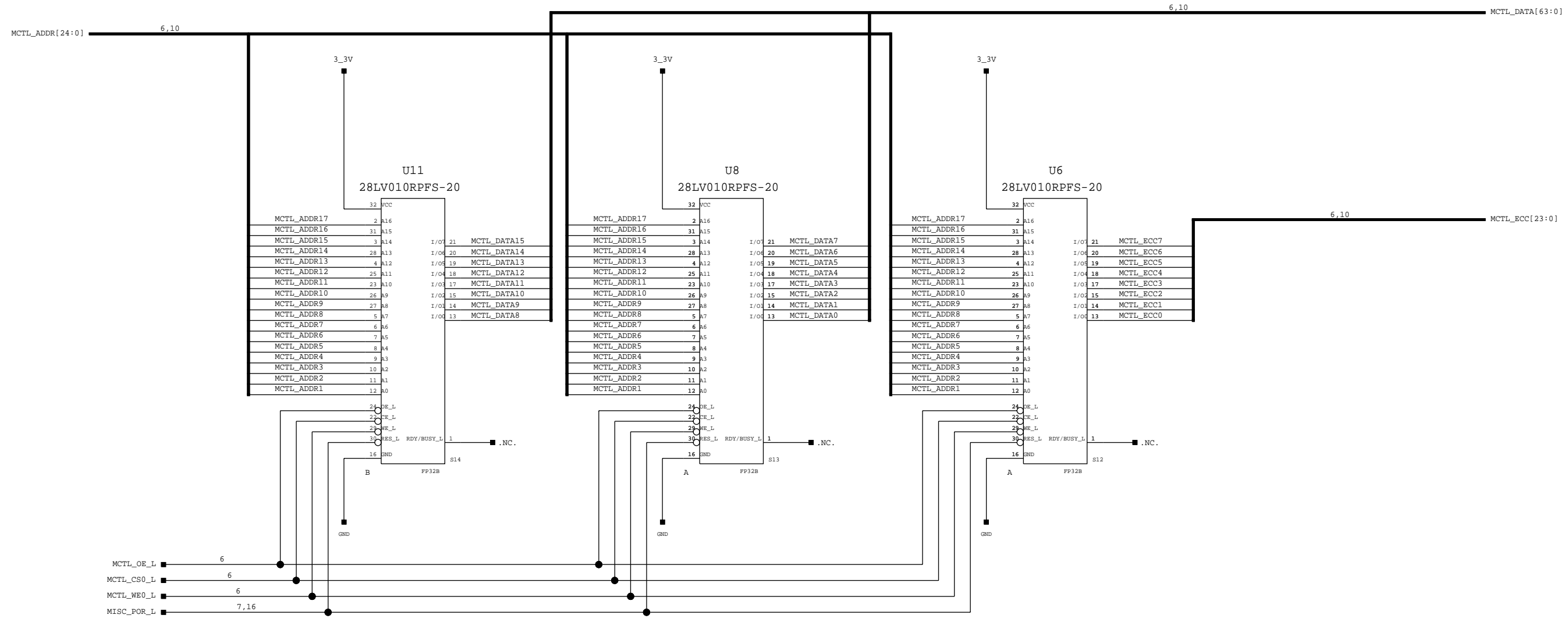

SIZE	CAGE CODE	DRAWING NO.	LD234A511
B	52088	SUROM	

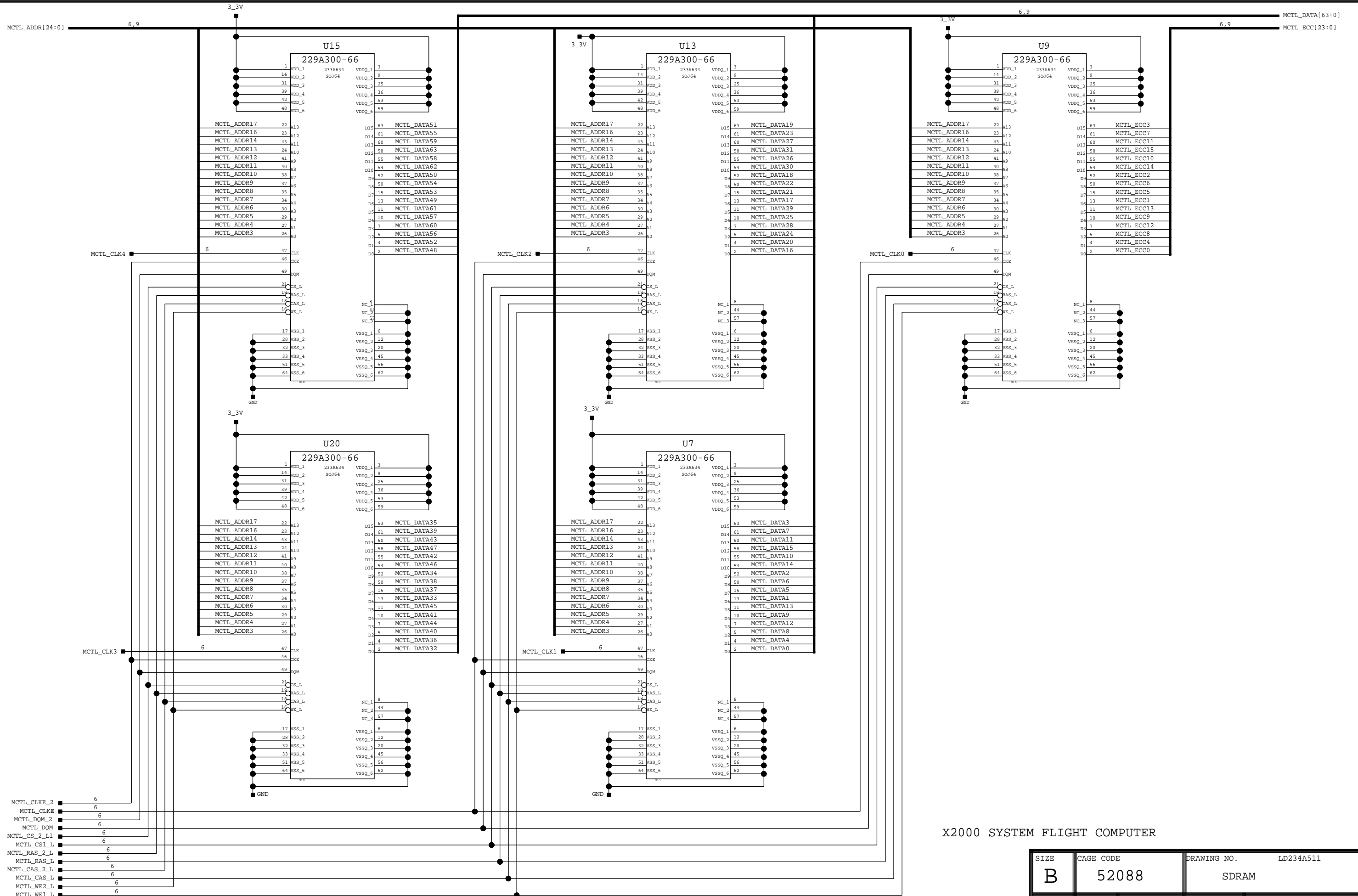

X2000 SYSTEM FLIGHT COMPUTER

SIZE	CAGE CODE	DRAWING NO.	LD234A511
B	52088	SDRAM	

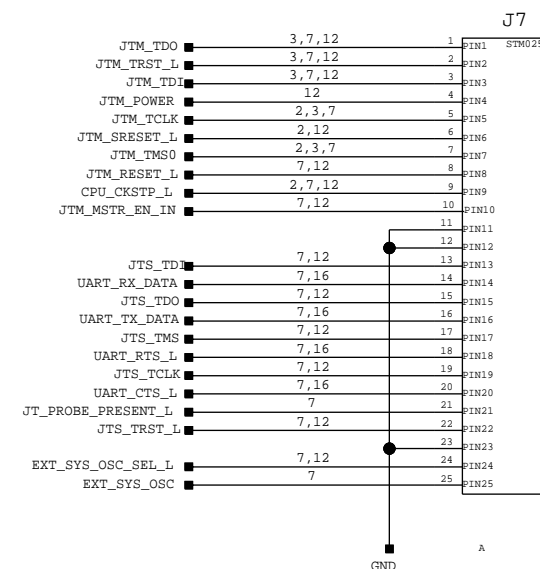
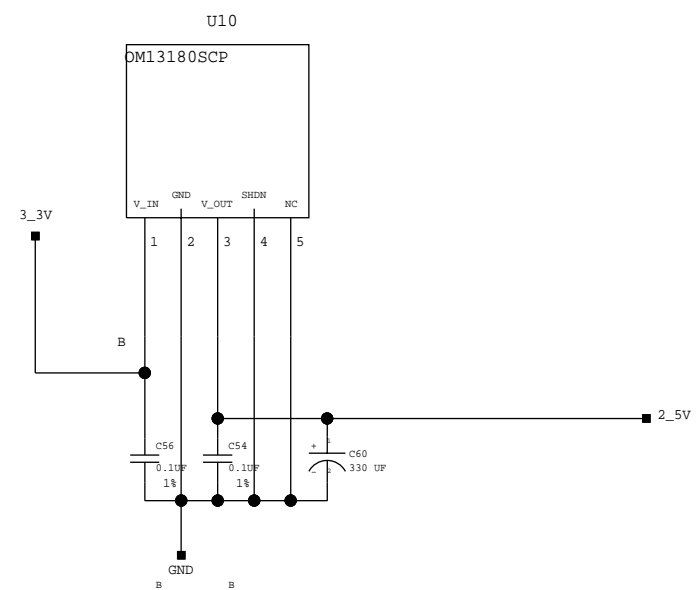
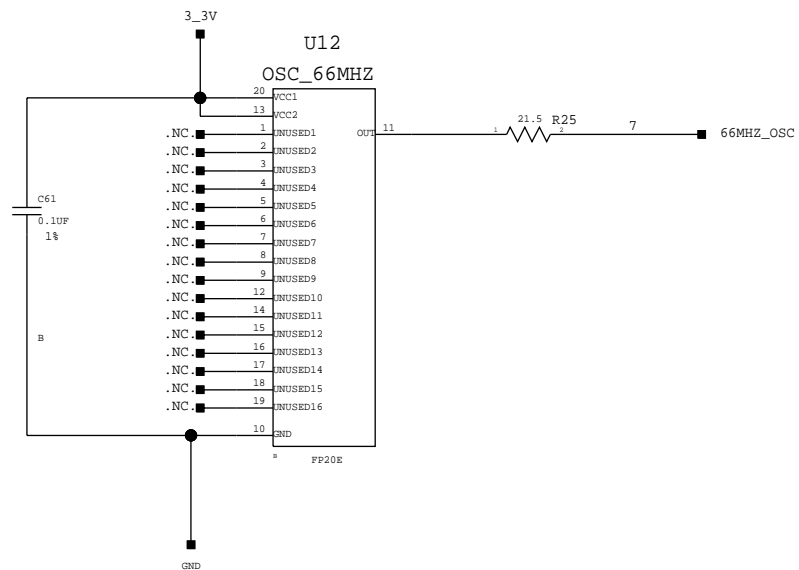

SIZE	CAGE CODE	DRAWING NO.	LD234A511
B	52088	OSCILLATOR / VOLTAGE REGULATOR	

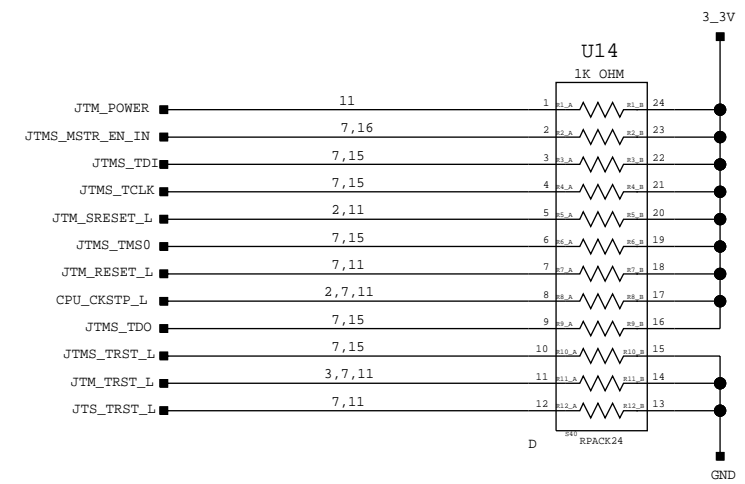
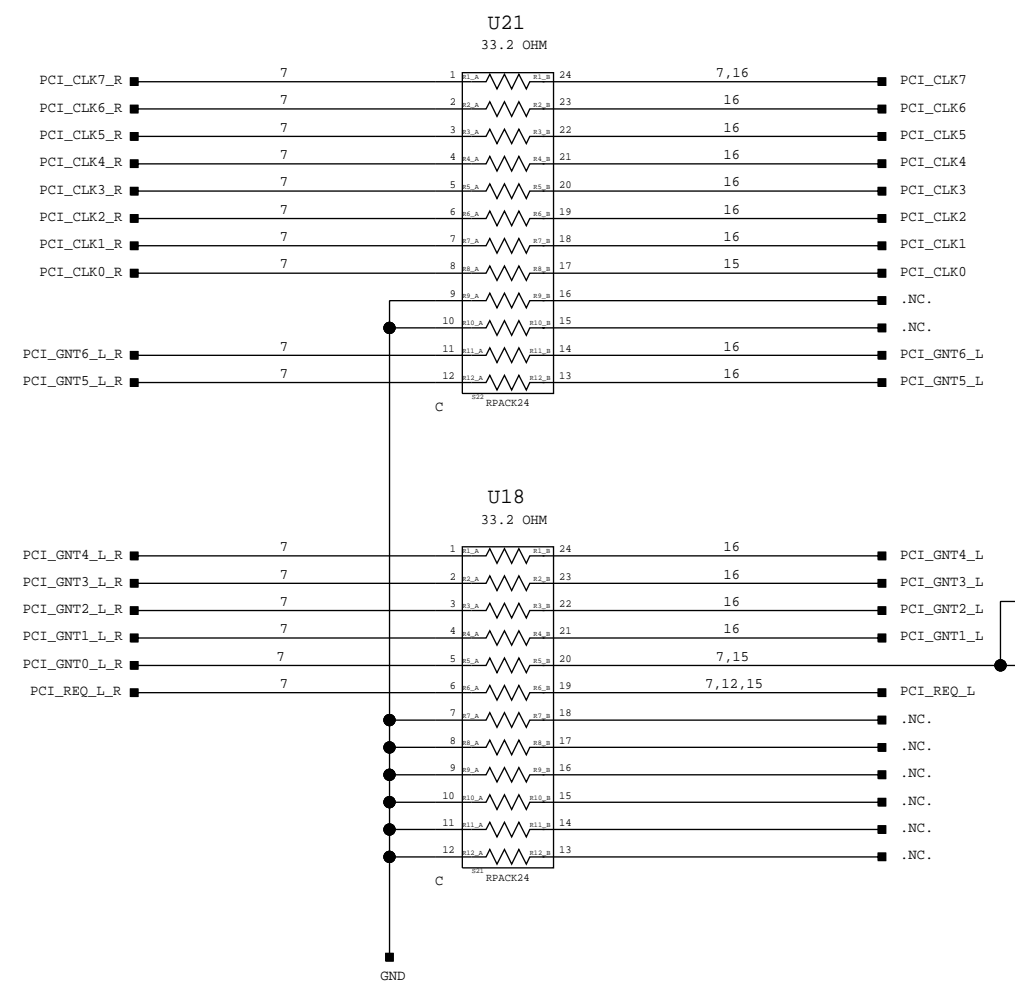
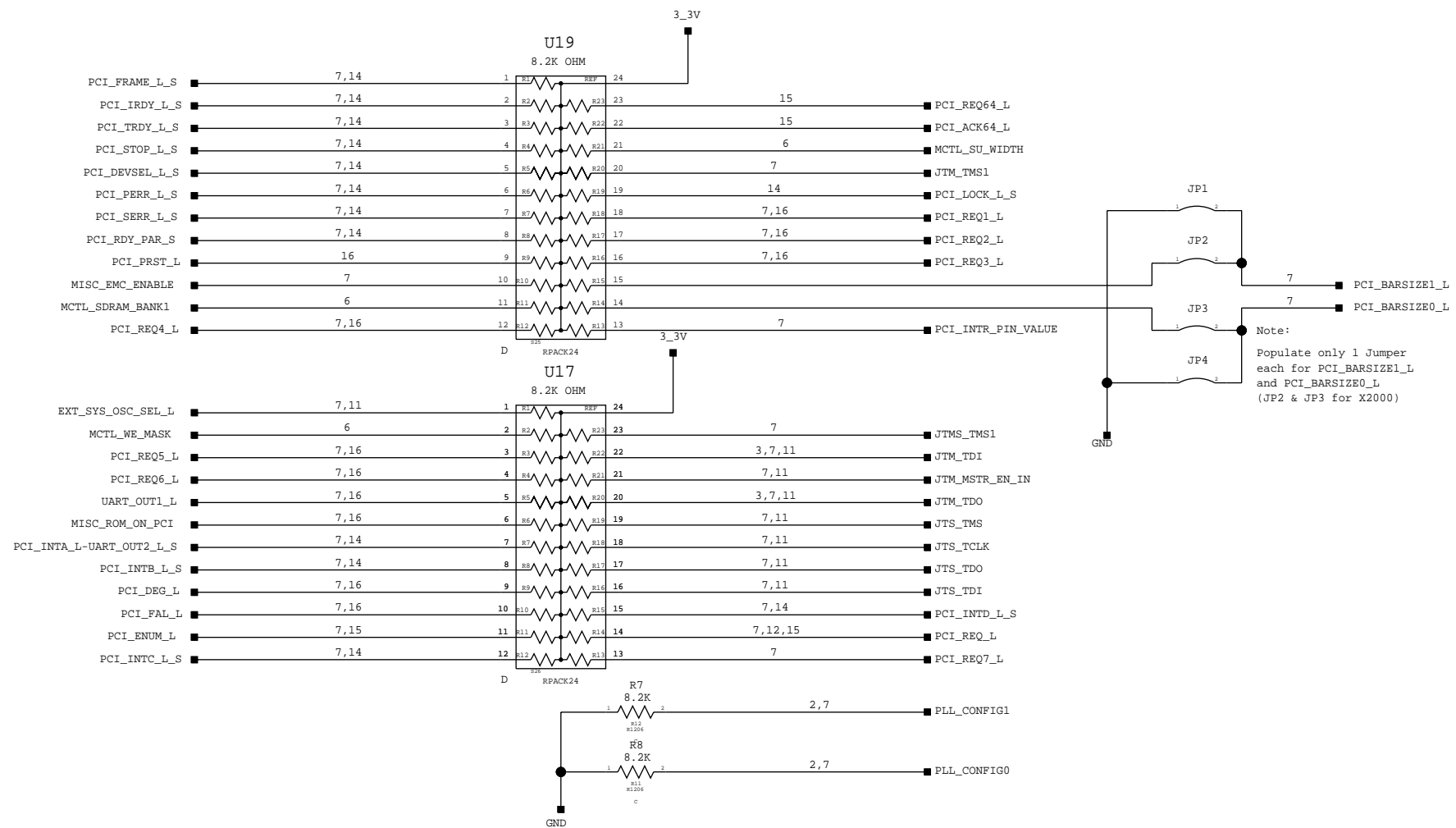

SIZE	CAGE CODE	DRAWING NO.	LD234A511
B	52088	COMPACT PCI CONNECTOR, J1	

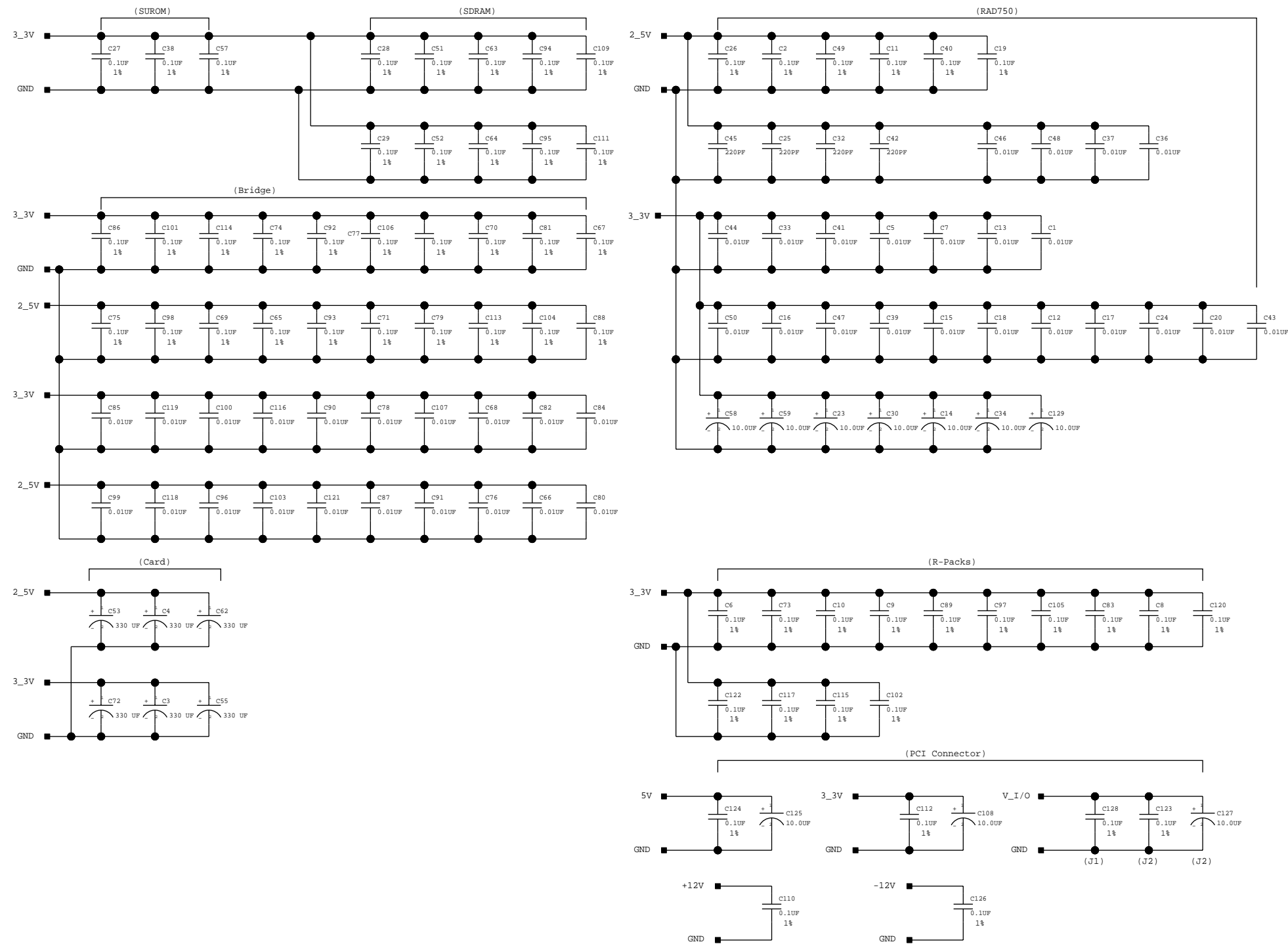

SIZE	CAGE CODE	DRAWING NO.	LD234A511
B	52088	CAPACITORS	

PCI_AD[0:31]_S 7

15 PCI_AD[0:31]

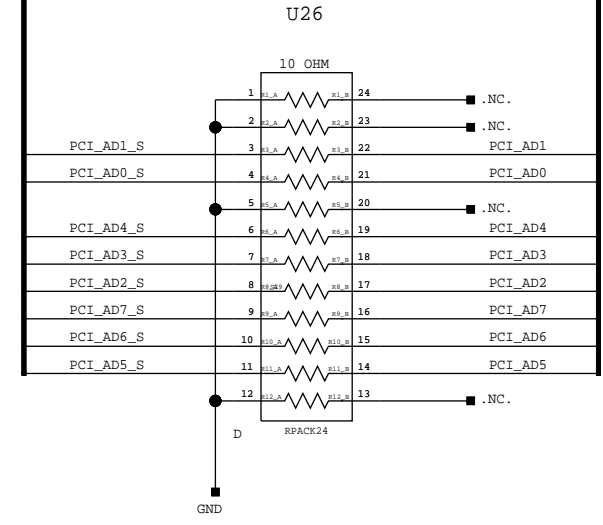
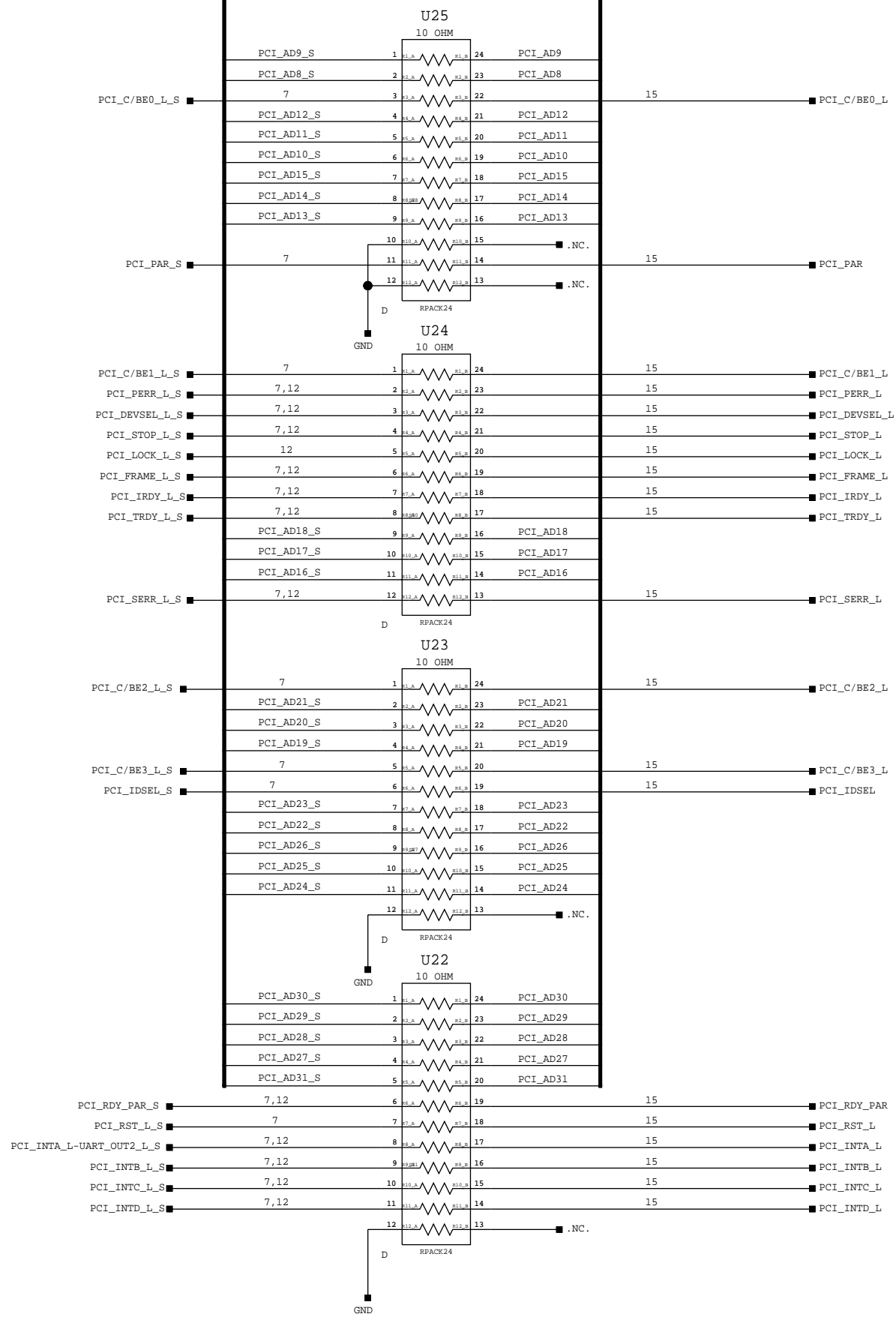

SIZE B	CAGE CODE 52088	DRAWING NO. LD234A511
PCI 10 OHM STUB TERMINATION		

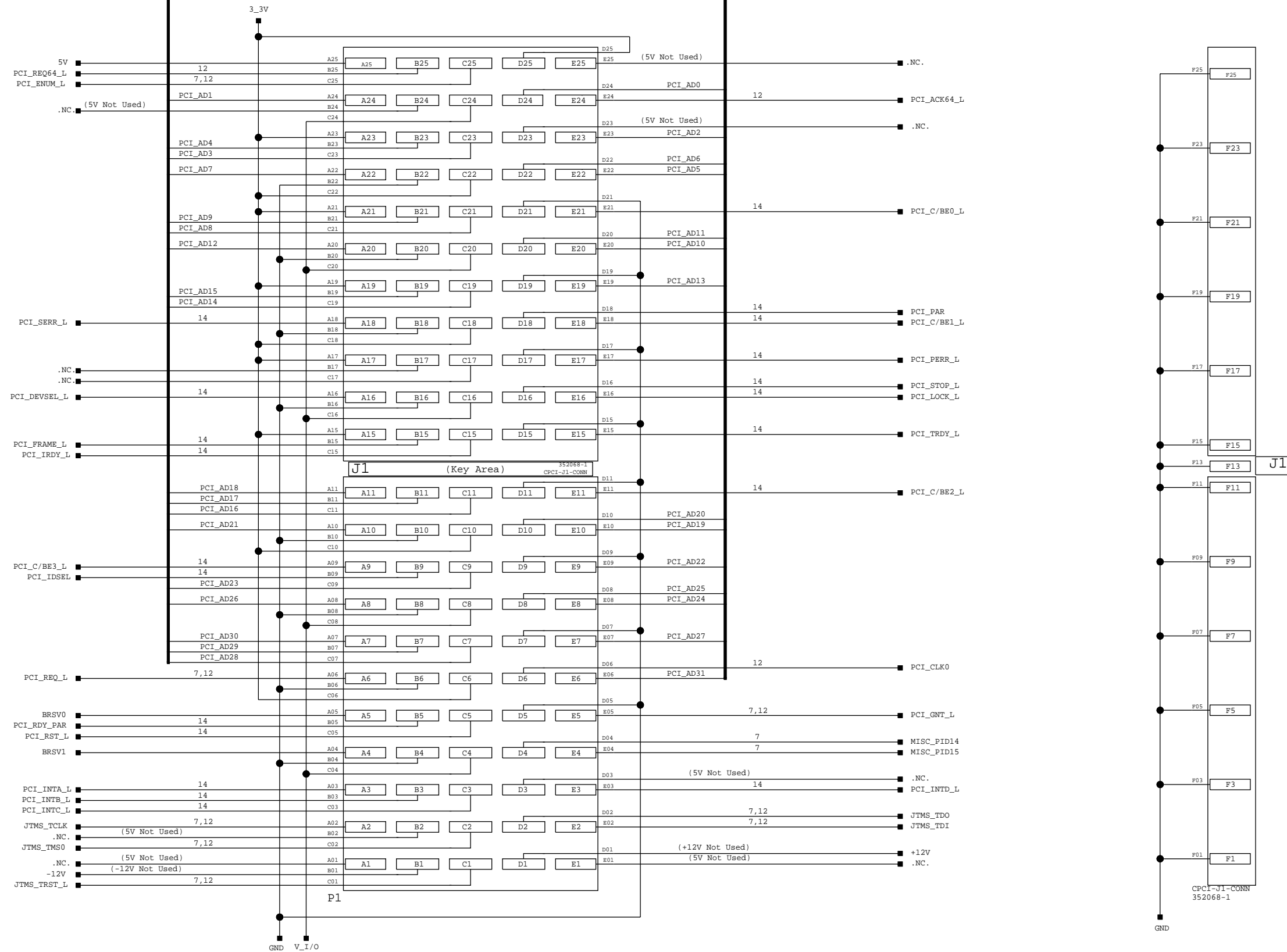

SIZE	CAGE CODE	DRAWING NO.	LD234A511
B	52088	COMPACT PCI CONNECTOR, J1	

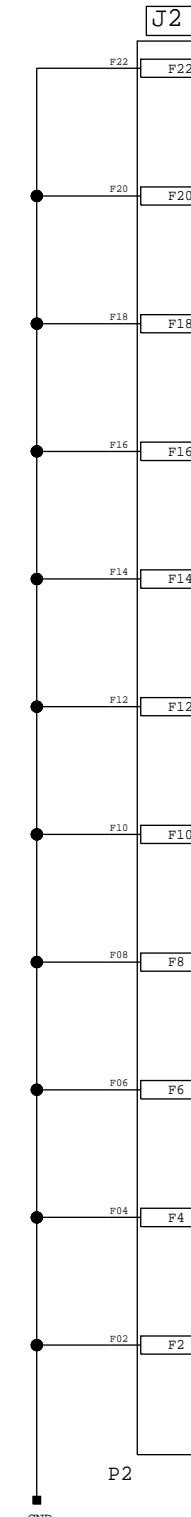
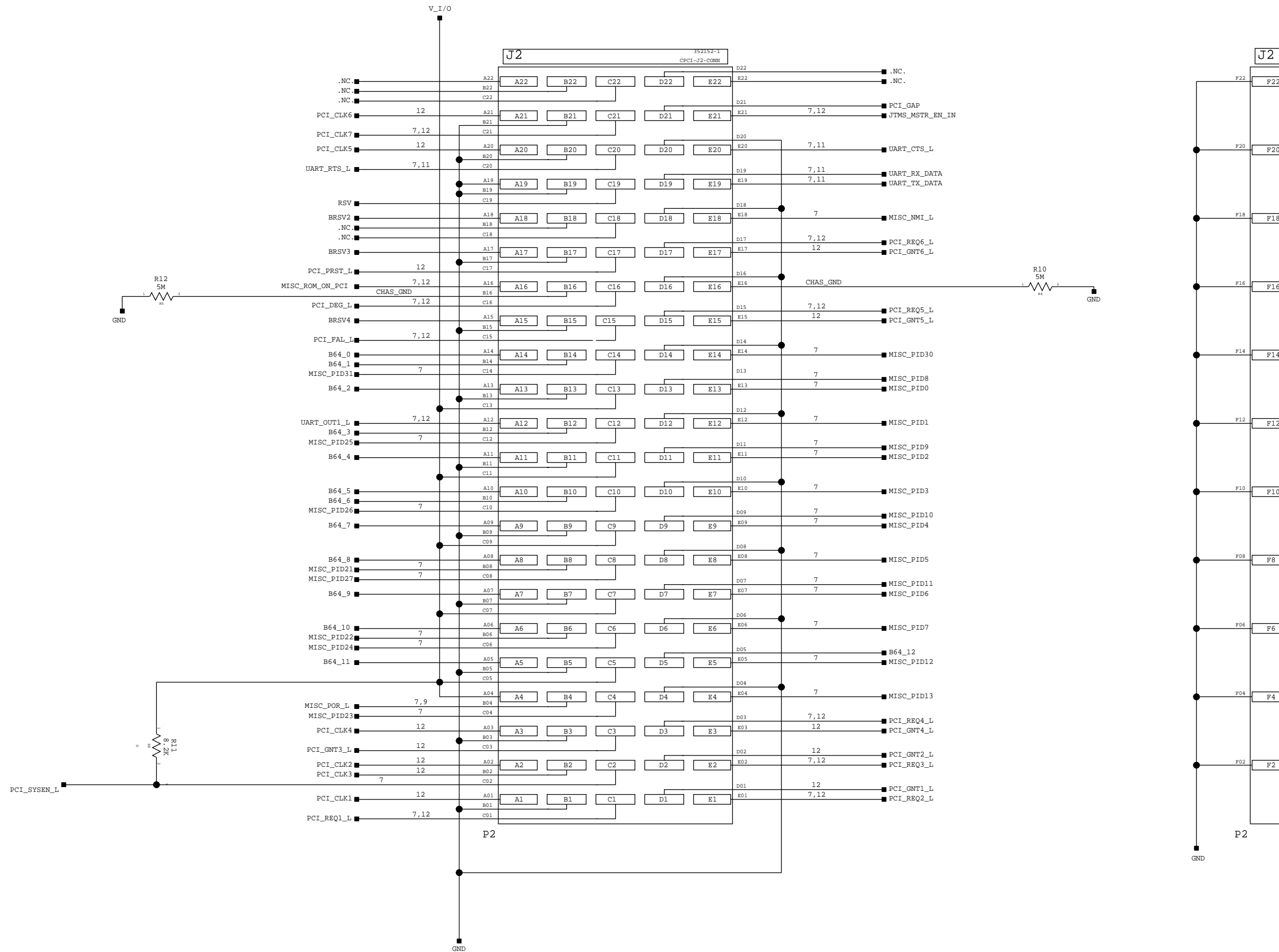

SIZE	CAGE CODE	DRAWING NO.	LD234A511
B	52088	COMPACT PCI CONNECTOR, J2	