

# Pipelining

# Scope of This Module

- This topic can be developed into an entire short course.
- This module not yet developed; that is in the roadmap for this set of design seminars.
- One topic is quite relevant to the design of reliable machines that designers should consider ...

# Basic Pipeline Architecture

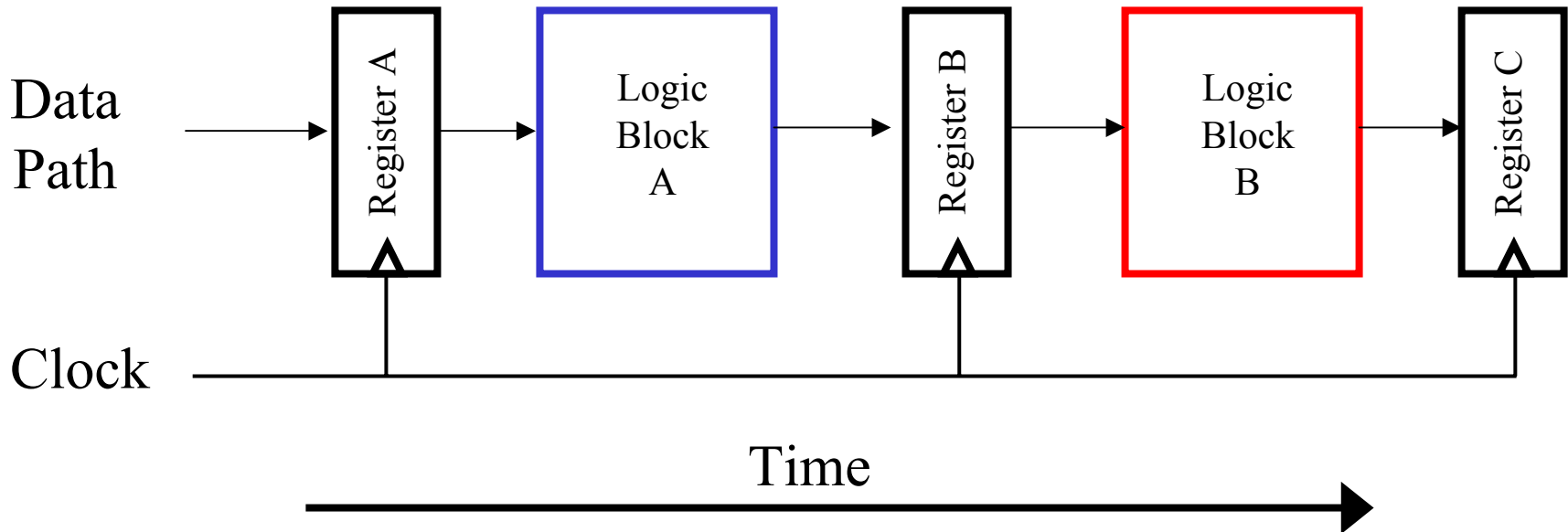

In this case the delay of each logic block is identical.

Assumption: Use single phase, single edge clock architecture

# Basic Pipeline Architecture

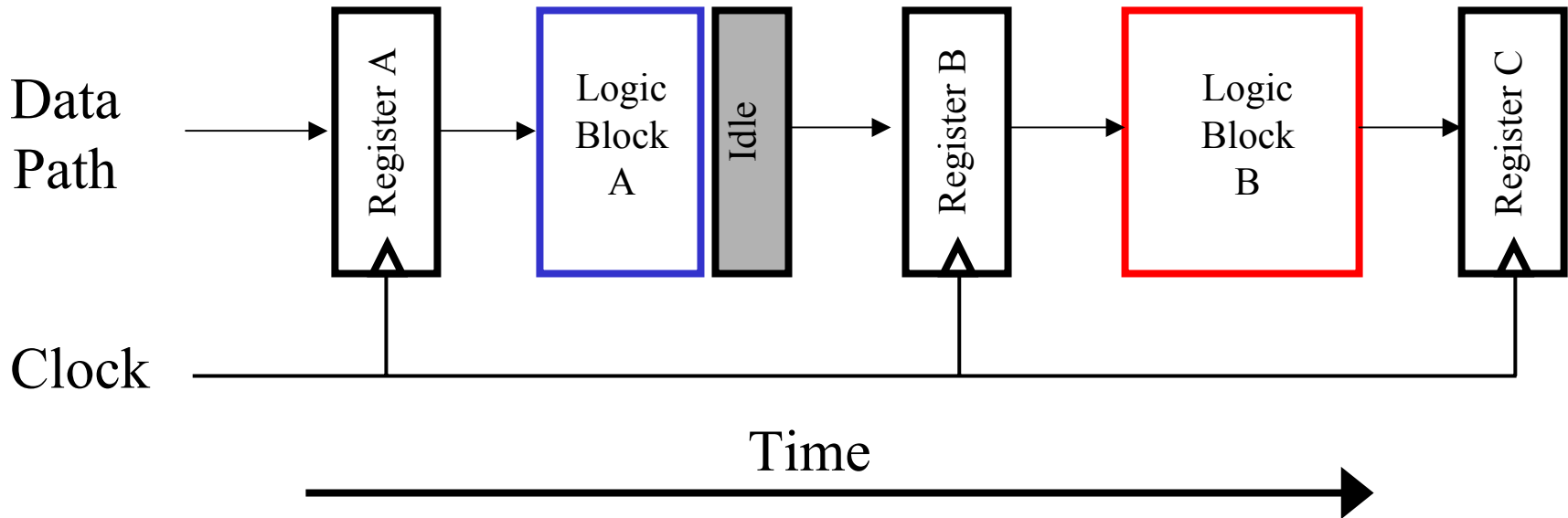

In this case the delay of each logic block B is greater than the delay of combinational logic block A.

Assumption: Use single phase, single edge clock architecture

# Basic Pipeline Architecture

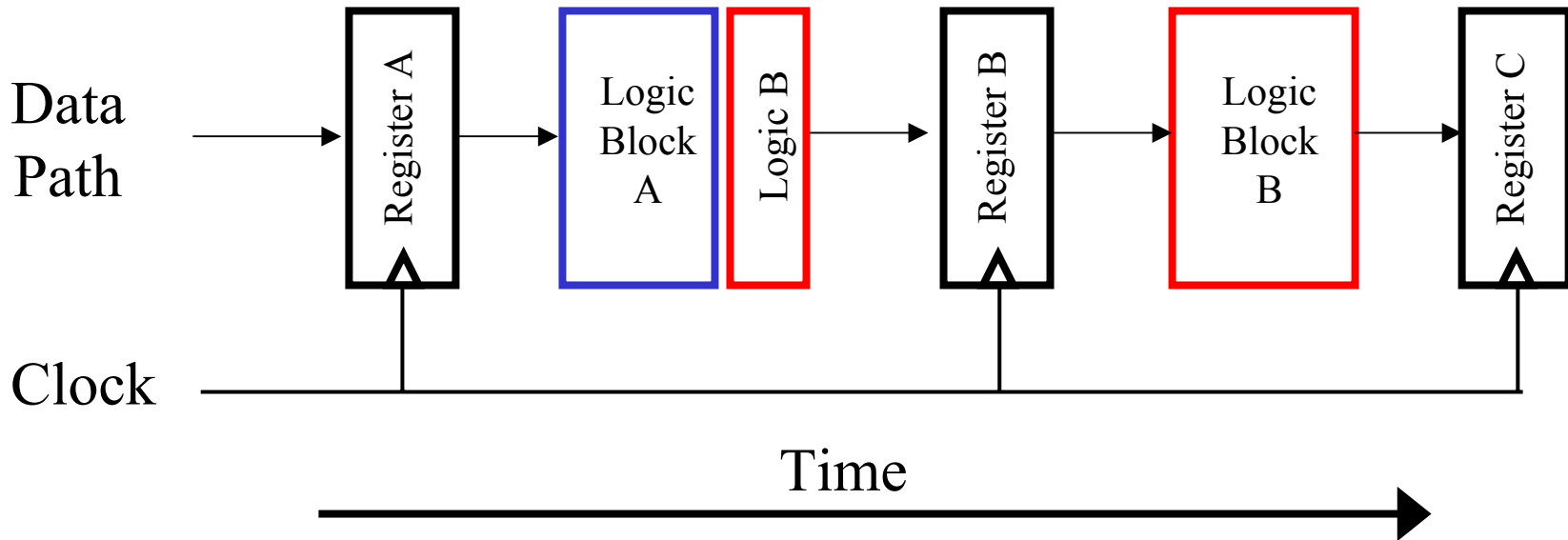

Clock frequency can be maximized by proper partitioning of the logic (or by intentionally skewing the clock).

Assumption: Use single phase, single edge clock architecture

# Who Is The Designer?

- In the old days, the pipelining was designed by engineers working with schematics.
- In modern times, the pipelining was designed by engineers working with RTL HDL.
- Now, we see software, written by someone we don't know, with algorithms that are hidden, changing the logic design and pipelining ...
  - What is the impact to structures for mission critical systems?